

Tracked Paver

# SUPER 1700-3i



# PERFECT IN ALL CLASSES

The right paver for every job

VÖGELE's seamless product range is considered unique in the industry. Whether a service road or a highway, an airfield or a race track, a new construction or a rehabilitation job, thick or thin, hot or cold - customers will find the right machine in our paver range for every paving task.



## VÖGELE PRODUCT RANGE

### MINI CLASS

- > Maximum paving width  
10 ft. 6 in. (3.2 m)
- > Maximum laydown rate  
275 tons/h (250 tonnes/h)

### COMPACT CLASS

- > Maximum paving width  
16 ft. 5 in. (5 m)
- > Maximum laydown rate  
385 tons/h (350 tonnes/h)

### UNIVERSAL CLASS

- > Maximum paving width  
21 ft. (6.4 m)
- > Maximum laydown rate  
770 tons/h (700 tonnes/h)

### HIGHWAY CLASS

- > Maximum paving width  
31 ft. 11 in. (9.75 m)
- > Maximum laydown rate  
1,540 tons/h (1,400 tonnes/h)

### SPECIAL CLASS

- > SprayJet

# HIGHLIGHT OVERVIEW

Perfectly equipped



## DRIVE

### 01 Drive concept

- > Powerful engine complying with US EPA standard Tier 4f.

### 02 VÖGELE EcoPlus

- > The VÖGELE EcoPlus low-emissions package significantly reduces fuel consumption and noise levels.

## QUALITY

### 03 Niveltronic Plus - the System for Automated Grade and Slope Control

- > Fully-integrated system perfectly matched to the machine technology of VÖGELE road pavers.
- > Wide range of sensors for flexible use in all fields of application.
- > User-friendly operation and monitoring of all Niveltronic Plus functions.

## MATERIAL MANAGEMENT

### 04 Receipt of mix

- > Advanced design provides precise material handling.
- > Optimum feeding with mix thanks to the large material hopper.

## OPERATION

### 05 ErgoPlus 3 operating system

- > ErgoPlus 3 with numerous additional ergonomic and functional advantages.

## VERSATILITY

### 06 Wide range of applications

- > 8-foot tracked Universal Class paver with a large range of applications and paving widths up to 21 ft. (6.4 m)

### 07 The right screed for every application

- > The paver can be combined with the VF 500 or VR 500 Extending Screeds.



**VÖGELE**  
SUSTAINABILITY

VÖGELE SUSTAINABILITY describes innovative technologies and solutions that are consistent with the sustainability objectives of the WIRTGEN GROUP.



01



02



03



04



05



06

# THE NEXT GENERATION

SUPER 1700-3i - the versatile asphalt paver

**The VÖGELE SUPER 1700-3i is a cutting-edge 8-foot-class paver suitable for a wide variety of applications. Typical jobs are the building of secondary roads and highways. Due to its compact design, the tracked paver is also ideal for commercial and municipal paving jobs.**

The SUPER 1700-3i also comes with the latest version of our operating system, the popular ErgoPlus 3, which has been enhanced with a number of new ergonomic and functional features. With its new mounting system, the paver operator's console can be shifted conveniently and easily between the right and left sides of the operator's stand during operation. ErgoPlus 3 also offers unobstructed operator visibility of the material hopper, auger tunnel and screed.

In addition, it now has a large color display that ensures good readability even in poor lighting conditions. The screed consoles have been completely redesigned, making operation of this "Dash 3" machine even easier for the entire paving crew.

With its Universal Class paver, VÖGELE also offers the right screed for every application. The SUPER 1700-3i can be combined with the VF 500, a screed with front-mounted extensions, as well as the VR 500, a screed with rear-mounted extensions. All of these features make this Universal Class machine a truly SUPER paver!



**01** 8-foot tracked Universal Class paver with a large range of applications.  
**02** The VÖGELE EcoPlus low-emissions package significantly reduces fuel consumption and noise levels.  
**03** Advanced design provides precise material handling.

**04** ErgoPlus 3 with numerous additional ergonomic and functional advantages.  
**05** Optimum feeding with mix thanks to the large material hopper.  
**06** The right screed for every application. The paver can be combined with the VF 500 and VR 500 Extending Screeds.

# LARGE RANGE OF APPLICATIONS

The SUPER 1700-3i is ideal for applications which require a variable paving width, such as car parks with islands and light masts, roads for residents only, urban roads with manhole covers, gas or water connections, junctions on highways or work on country roads, i.e. jobs which involve paving around obstacles. Two screed options are available for the SUPER 1700-3i: The paver can be combined with the VF 500 for multivariable width applications or the VR 500 for mainline applications. With a basic width from 8 ft. to 15 ft. 6 in. (2.45 m to 4.75 m) and a maximum paving width of 19 ft. 6 in. (5.95 m) with bolt-on extensions for the VF 500 and a basic width from 8 ft. 4 in. to 16 ft. (2.55 m to 4.9 m) and a maximum paving width of 21 ft. (6.4 m) with bolt-on extensions for the VR 500 these screeds are the ideal tools for multivariable width applications of the SUPER 1700-3i.



- 01 Asphalt paving on surfaces used for industrial purposes
- 02 Asphalt paving on combined foot and cycle paths
- 03 Pavement rehabilitation on municipal roads
- 04 Pavement rehabilitation on access roads

# STATE-OF-THE-ART DRIVE TECHNOLOGY

Three main components define the power unit of a SUPER 1700-3i: its modern, liquid-cooled diesel engine, a splitter gearbox flanged directly to the engine and a large cooler assembly.

The driving force in this power pack from VÖGELE is its diesel engine. The four-cylinder engine delivers 173 hp (129 kW) at 2,000 rpm. Yet the fuel-saving ECO mode is sufficient for many applications. And even then, the SUPER 1700-3i still has a full 160 hp (119 kW) at its disposal. Moreover, the machine generates even less noise when running at just 1,700 rpm.

A large cooler assembly ensures that the power unit always delivers its full output. With innovative air routing and a variable-speed fan, temperatures are continually maintained within the optimum range, significantly extending the service life of both the diesel engine and the hydraulic oil. A further advantage is that the machine can operate without difficulty in all climate regions worldwide.

**173 hp (129 kW)**  
diesel engine output

**ECO mode**  
reduces operating costs

**58 gallons (220 liters)**  
Capacity fuel tank



■ = Coolant  
■ = Charge air  
■ = Hydraulic oil

All hydraulic elements are supplied with hydraulic oil directly from the splitter gearbox, the advantage being that all pumps and valves are combined in one spot that is easily accessible for maintenance work. Even the powerful and completely maintenance-free generator for screed heating is flanged directly onto the splitter gearbox.

The fuel tank holds 58 gallons (220 liters), more than enough for a day's work. The SUPER 1700-3i additionally has a DEF tank with sufficient capacity.



### Exhaust emissions after-treatment and VÖGELE EcoPlus

On engines conforming to exhaust emission standard US EPA Tier 4f, exhaust emissions after-treatment is provided by the diesel oxidation catalyst (DOC) and a selective catalytic reduction (SCR) catalytic converter.

VÖGELE EcoPlus also significantly reduces emissions. This package is capable of cutting consumption and CO<sub>2</sub> emissions by up to 25%, as well as reducing noise.

# VÖGELE ECOPLUS

Less is more

It goes without saying that our road pavers conform to the applicable emissions directives, but we like to go much further. That's why the machine concept of the "Dash 3" generation uses environmentally friendly innovations in machine technology, resulting in lower consumption, lower emissions and lower costs.

One of these innovations is the VÖGELE EcoPlus low-emissions package. Fuel savings of up to 25% can be achieved with VÖGELE EcoPlus, depending on the application and capacity utilization of the paver. That doesn't just result in considerable savings for the contractor - it is good news for the environment, too. That's because every liter of fuel saved reduces carbon dioxide (CO<sub>2</sub>) emissions.



## VÖGELE SUSTAINABILITY



**25% fuel saving**



**25% less CO<sub>2</sub> emitted**



**Lower noise emissions**



### VÖGELE > GOOD TO KNOW



#### The technical innovations



**Splitter gearbox with ability to disengage hydraulic pumps**  
When the paver is stationary, all the hydraulic pumps needed for "traction", "conveyors and augers" and "compaction" are disengaged automatically. The result? Lower fuel consumption.

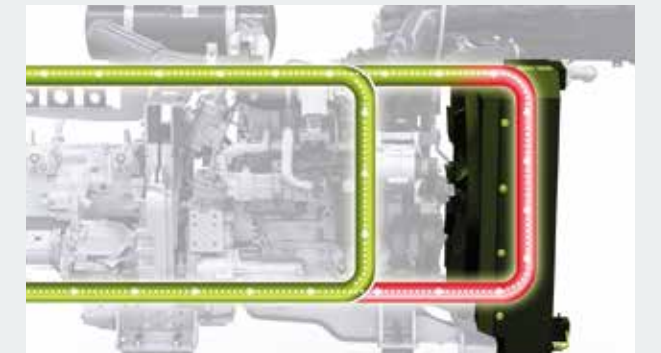

**Controlled hydraulic oil temperature circuit**  
A bypass circuit gets the hydraulic oil to its optimum operating temperature very quickly, enabling rapid, fuel-saving operation of the paver.



**Variable-speed fan**  
The variable-speed fan automatically adapts to the engine load and the ambient temperature. This type of drive saves energy and reduces noise emissions.

# EFFICIENT TRANSLATION OF TRACTIVE POWER

A strong point of the SUPER 1700-3i are the continuous rubber tracks. Due to the large track width of 14 in. (355 mm), paving speeds up to 250 fpm (76 m/min.) are possible. The large footprint also provides excellent flotation and tractive effort. The powerful, separate drives are integrated directly into the drive wheel of the rubber track, meaning that engine output is transmitted without any loss of power.

As a result, the SUPER 1700-3i can push any feed truck with ease. The SUPER 1700-3i also displays impressive maneuverability and high mobility. It can turn on the spot and easily masters difficult terrain with inclines and slopes.

> Continuous rubber tracks, 14 in. (355 mm) wide, with self-aligning front idlers provide for optimal steering under any conditions. Dual track tensioning cylinders provide perfect alignment.

> Powerful track drives and engine output deliver maximum torque with no loss of power.

> Large footprint ensures maximum tractive effort and high flotation, allowing the paver to work at a constant speed even when operating on difficult terrain.

> The most advanced steering control in the industry provides precise straight-line tracking and smooth, accurate turns.

**Hydraulic drives**  
directly in the sprockets

**Consistent straight running**  
thanks to separate electronically-controlled drives

**Long crawler tracks**  
for maximum traction



# PRECISION PAVING WITH MATERIAL MANAGEMENT

A continuous flow of mix is key to ensuring uninterrupted and high-quality paving. That is why we attach such importance to professional material management when designing our pavers. Thanks to its large material hopper, the SUPER 1700-3i can be supplied with material easily and quickly.

To prevent segregation a number of design and technical features are installed in the paver which help keep the paving material in a highly homogeneous state on its way through the paver from the material hopper to the screed.

The hydraulically operated hopper apron prevents material spills during truck exchanges. It directs the material inside the hopper directly onto the conveyors, so no hand work is required. All of the mix is properly conveyed to the screed.



**Large material hopper**  
with a capacity of 14.3 tons (13 tonnes)

**Deep and wide hopper sides**  
for especially straightforward material feed

**Push-rollers**  
oscillating



**01** Independently operated hopper wings.  
**02** The large material hopper holds 14.3 tons (13 tonnes).

- > The large material hopper holds 14.3 tons (13 tonnes) and is dimensioned so that plenty of mix is stored at all times.
- > Sloped inner design of the hopper for an optimal flow of material to prevent segregation.

- > Easy feeding with mix thanks to only 24 in. (620 mm) dump height, wide hopper wings and sturdy rubber flashing fitted to the hopper apron.
- > Independently operated hopper wings.

## VÖGELE > GOOD TO KNOW

### Truck hitch

Large oscillating push-rollers can be set to 2 different positions for convenient and shock-free docking of feed vehicles even in curves. A truck hitch is available as an option.



# PRECISION MATERIAL DELIVERY PREVENTS SEGREGATION

Thanks to effective spreading of the material, the SUPER 1700-3i always has an optimal head of mix in front of the screed to meet the demands of every paving situation. The wide conveyor tunnel and powerful, hydraulic separate drives on the conveyors and augers support high laydown rates of up to 770 tons/h (700 tonnes/h).

- > Proportional control and continuous monitoring of conveyors and augers guarantee a constant head of material in front of the screed.
- > Inclined conveyors from the front to the rear of the machine provide ideal delivery of the material onto the augers.



Narrow conveyor guard in the material hopper guarantees uniform material flow.



- > Large, 16 in. (40 cm) diameter auger flights with precision pitch ensure excellent spreading of the material when paving in large widths or at lower engine rpm. VÖGELE's unique flight design provides prolonged service life versus standard flight designs.

- > The optional Power Tunnel is perfect for changing paving widths. The hydraulically adjusted limiting plates adapt to the screed width automatically, ensuring an optimal head of mix in front of the screed all the way to the end gates, even when the screed extensions are fully moved out.

## VÖGELE > GOOD TO KNOW

### Adjustable augers

Hydraulically adjustable augers are infinitely variable in height within a range of 6 in. (15 cm). Hydraulic auger height adjustment (including bearing boxes and limiting plates for the auger tunnel) provides optimal spreading of the material even when paving thin layers or on sections where thickness varies.

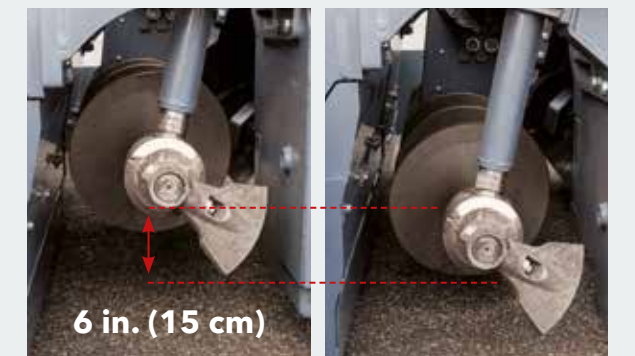



## THE ERGOPLUS 3 OPERATING SYSTEM

Improved efficiency, reliability and convenience

Even the very best machine with the most advanced technology can only really show its strengths if it can be operated easily, and as intuitively as possible. At the same time, it should offer an ergonomic and safe working environment for the operating team. Therefore, the ErgoPlus 3 operating system focuses on the operator. With VÖGELE pavers, the operator consequently retains full control over the machine and construction project.

On the following pages you will find detailed information on the extensive functions of the ErgoPlus 3 operating system. ErgoPlus 3 encompasses the operator's stand, the paver operator's console, the screed console and Niveltronic Plus, the System for Automatic Grade and Slope Control.



# THE ERGOPLUS 3 PAVER OPERATOR'S CONSOLE

Clearly arranged in line with experience from the field

The paver operator's ErgoPlus 3 console has been designed according to practice-related principles. All controls are clearly arranged. Paver functions are clustered in logical groups so that operators find their controls just where they would expect them to be.

On the ErgoPlus 3 console, all push-buttons are easily identifiable by touch even when wearing work gloves. Once a button is pressed, off you go thanks to the "Touch and Work" principle. This means that a function is executed directly - without the need to confirm.



## 01 Conveyors and augers, traction

All controls for the conveyor and auger are located here. The traction main switch, the operating mode selector and the setpoint adjuster for the pave speed are also included in this function group.

## 02 Material hopper and steering

This function group includes the controls for the material hopper, the steering and the diesel engine. Various options are also operated from here.

## 03 Screed functions

All controls for the screed are grouped in the center of the paver operator's console.

## 04 Display of the paver operator's console

The redesigned color display has a high-contrast user interface ensuring brilliant readability even in poor lighting conditions. Vital information is shown on menu level 1, such as the positions of the screed tow point cylinders or the material level in the conveyor tunnel. Further paver functions such as speeds for tamper and vibration or feed rates for the conveyors can easily be set up via the display, too. And the display gives access to machine-related information such as fuel consumption or service hours.

## 05 Safe operation during the night

Glarefree backlighting comes on automatically as darkness sets in so that the paver operator can also work safely on night-time jobs.



# CONVEYORS AND AUGERS, TRACTION

## Module 1

### 01 Reversing conveyor movement

In order to avoid mix dropping from the conveyors during a move of the paver on the job site, conveyor movement can be reversed at the push of a button. Reverse movement, transferring mix from the rear of the conveyor tunnel back inside, takes place for a short time only and stops automatically.

### 02 Automatic functions

For conveyors and augers, operators can easily select Manual mode or Automatic mode. When selecting Automatic mode for the augers, sensors installed for the material level in the auger tunnel provide that exactly the desired amount of mix is spread in front of the screed.



The conveyor can be reversed at the touch of a button. Return transport of the mix is automatically stopped. The conveyor can be switched to the no-load function just as quickly.



01 Reversing conveyor movement

02 Automatic functions

03 No-Load function

04 Choice of operating modes for the paver

### 03 No-Load function

The No-Load function is provided for the warm-up or cleaning of conveyors, augers and tamper.

### 04 Choice of operating modes for the paver

On the ErgoPlus 3 console, 4 different operating modes for the paver are available to select from. By pressing the arrow buttons, up or down, the operator changes modes in the following order: "Neutral", "Job Site", "Positioning" and "Paving". An LED indicates the mode selected. When leaving "Pave" mode, a smart Memory feature stores the last settings for paver functions so that, when resuming work after a move of the paver on site, these settings are restored automatically.

# MATERIAL HOPPER AND STEERING

## Module 2

### 01 Choice of engine speed ranges

For the engine, there is a choice of 3 modes to select from: MIN, ECO and MAX. To switch modes for engine rpm, all the operator needs to do is press the arrow buttons, up or down. In ECO mode, the engine delivers sufficient power for a great number of paving applications. Operating in ECO mode reduces noise emission and fuel consumption considerably.

### 02 Steering with preselected steering angle

The machine is steered by means of an easy-grip rotary controller which enables the paver operator to maneuver the machine precisely even in the tightest spots. For long curves with a constant radius, the desired steering angle can be preselected using arrow keys. The paver stays automatically on the set track until the function is deactivated again, allowing the paver operator to monitor the paving process undisturbed.



01 Choice of engine speed ranges  
 02 Steering with preselected steering angle  
 03 Truck Hitch

- 01 Choice of engine speed ranges
- 02 Steering with preselected steering angle
- 03 Truck Hitch (Option)
- 04 Independently operated hopper wings



# SCREED FUNCTIONS

## Module 3

All the key screed settings can be made from the paver operator's console. The screed can be raised or lowered here, and each of the two sides of the screed extended or retracted, or the angle of the screed adapted to suit conditions. This means the paver operator also has access to the screed at all times.

### 01 Screed lock

When the paver is in the transport position, the screed is secured by locking bolts. When the screed is raised, the two locking bolts can be retracted by the hydraulic screed lock at the touch of a button.

### 02 Screed heating

To optimize compaction and produce a smooth surface texture, all compacting elements are heated across the full screed width. A simple touch of a button is all it takes to switch screed heating on or off. To ensure the screed heating system is working properly, an automatic function check is carried out when it is switched on.



01

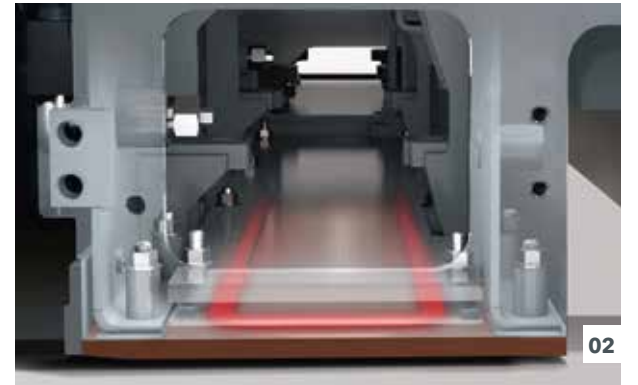

02

- 01 Locking bolts on both sides secure the screed in its transport position.
- 02 Screed plates are fitted as standard with heating elements which distribute the heat all over the plates.
- 03 When the screed is in the floating position, the Screed Assist feature can also be activated.



03

### 03 Screed Assist

This button switches Screed Assist on (LED lights up) or off. Screed Assist pressure and balance can be set on the display. Screed Assist is active only when the screed is floating.

01 Screed lock

02 Screed heating

03 Screed Assist



# THE ERGOPLUS 3 SCREED CONSOLE

The screed is crucial for pavement quality. Therefore, easy and positive handling of all screed functions is of utmost importance for high-quality road construction.

With ErgoPlus 3, the screed operator has the process of paving at his fingertips. All functions are easily comprehensible and all controls are clearly arranged.

The screed console is designed in keeping with the conditions prevailing on the job site. Push-buttons are provided for the frequently used functions operated from the screed console. These are watertight and enclosed in palpably raised rings, so that they are identifiable blindfolded simply by touch even when wearing work gloves. Important paver and screed data can be called up and adjusted from the screed console, too.



**01** The screed console is specially designed for night-time operation. To prevent operator errors, the buttons are backlit as soon as dusk falls or in darkness. What is more, the downward-angled high-power LED lighting gives the operator a perfect view of all processes associated with the end gate.

**02** The screed width can be effortlessly adjusted by means of the "SmartWheel".

## 01 The display of the screed console

The screed console display allows the screed operator to control and monitor both the left and the right side of the screed. Machine-related parameters such as vibration speed or conveyor speed can be adjusted conveniently via the display panel of the screed console. The clear menu structure, combined with easily understandable, self-explanatory symbols neutral in language, makes operating the display panel both simple and safe.

## 02 Ergonomic screed width control in two speeds

The screed width can be effortlessly adjusted by means of the "SmartWheel". This is done in two speeds: slow, for precise control e.g. along an edge, or fast, for rapid extension or retraction of the screed.

## 03 Crown adjustment at the press of a button

The crown can be conveniently adjusted at the press of a button on the screed operator's console. When pressing the "plus" or "minus" keys, the set crown value is shown on a pop-up window. The conveyors and augers are adjusted accordingly.

**01** The display of the screed console

**02** Ergonomic screed width control in two speeds

**03** Crown adjustment at the press of a button

# ERGOPLUS 3 REMOTE CONTROL UNIT FOR THE SCREED

In addition to the screed operating consoles, a compact and very durable remote control is available for each side of the VF 500 screed. The remote controls can be securely stowed in the holders on the main screed, or on the ends of the screed extensions.

The holders are magnetic, meaning that the remote controls are easy to grab at any time, giving the operator a large radius of movement so that he can always find the most effective working position in any paving situation.



- 01** Setting: Conveyor, automatic/manual
- 02** Setting: Auger, automatic/manual
- 03** Setting: Screed, tow point cylinder
- 04** Control: Screed width
- 05** Setting: Power tunnel, automatic/manual
- 06** Setting: Berm
- 07** Setting: Slope
- 08** Setting: Screed extension, height
- 09** Lock: Screed extension

All the main paving functions of the screed can be controlled using one of the two handy screed remote controls. Intuitive operation is possible thanks to self-explanatory and language-neutral symbols.

# NIVELTRONIC PLUS

System for Automatic Grade and Slope Control

Niveltronic Plus, the System for Automatic Grade and Slope Control, is an in-house development by VÖGELE based on many years of experience in grade and slope control technology. Easy operation, precision and reliability are its hallmarks, ensuring perfect mastery of all grade and slope control jobs.

This fully integrated system is optimally adapted to the machine technology of the Premium Line pavers. All wiring and connections, for instance, are integrated into the tractor, effectively eliminating all risk of damage to these components.

VÖGELE naturally offer a particularly large and practical selection of sensors permitting versatile use of the Niveltronic Plus system. Whether for instance car parks, roundabouts or highways need to be built or rehabilitated, VÖGELE offer the right sensor for every job site situation.

Sensors can be changed quickly and easily, for Niveltronic Plus automatically detects which sensor is connected, thus simplifying the configuration process for the user.



01



02



03

- 01 The LED sighting crosses also fitted to the sensor provide continuous, clearly visible feedback to the screed operator indicating whether the actual values match the settings made.
- 02 A variety of sensor types are available for Niveltronic Plus, in keeping with the machine's extensive and varied range of applications. These sensors extend from a mechanical sensor to non-contacting sonic sensors.
- 03 The two-way split display provides the screed operator with access to both sides of the screed. The symbols provide information at all times including on the height of the tow point rams, the preset and actual values, and the preset sensitivity of the grade and slope control sensors.



01

02

03

## VÖGELE > GOOD TO KNOW



### Available sensors

#### Slope sensor

The slope sensor allows the transverse profile to be determined exactly and then paved accurately. The measuring range is +/- 10%.

#### Variable mechanical grade sensor

The variable mechanical grade sensor can be equipped with skis for referencing from the ground in 30 cm, 1 m and 2 m lengths.

#### Single-cell sonic sensor

The single-cell sonic sensor emits a sound cone, allowing it to copy references 1:1 without calculating an average. It can be used for referencing from the ground (Ground mode) or from a tensioned wire (Stringline mode).

#### Multi-cell sonic sensor

The multi-cell sonic sensor, with its four sensors, is highly versatile. By calculating an average, it can compensate for short irregularities in a reference.

#### Big MultiPlex Ski

The Big MultiPlex Ski compensates for extended undulations. Its 5 to 13 meter (16.4 to 42.6 ft) beam can be fitted with three multi-cell sonic sensors as standard - or with up to five if required.



## THE ERGOPLUS 3 OPERATOR'S STAND

Improved efficiency, reliability and convenience

An ergonomic workstation is of key importance to enable a paver operator to concentrate fully for long periods of time, which is why VÖGELE relies on the paver operator's stand with ErgoPlus 3. The operator's ErgoPlus 3 stand provides plenty of storage space, is clearly arranged and meets stringent health and safety requirements.

Outstanding all-round visibility also increases safety. The operator can monitor everything from his workstation: material feed, material supply and head of mix. With its intelligent design, the ErgoPlus 3 system proves that innovative technology can be controlled ergonomically, efficiently, intuitively and conveniently.

### 01 The comfortable operator's stand

> The comfortable operator's stand gives an unobstructed view of all crucial areas on the paver such as material hopper, steering guide or screed. It allows the paver operator to closely monitor the paver's feed with mix and the process of paving.

### 02 Control console and seats can be moved for an optimum seated position

> The seats swing out to the sides and a streamlined operator's stand provides maximum visibility of the auger tunnel, permitting the paver operator to keep an eye on the head of mix in front of the screed at all times.  
> On the "Dash 3" machines, the paver operator's seat and console, as well as the screed consoles can now be adjusted even more easily to personal requirements.

### 03 Hardtop gives excellent protection

> The modern hardtop made of glass fiber reinforced polymer material shelters the operator whether rain or shine.

### 04 A place for everything and everything in its place

is well organized, offering the paver operator a professional workplace. The operator's console can be protected by a shatter-proof cover to prevent willful damage.

### 05 Consistent service concept

> All "Dash 3" pavers have a consistent maintenance concept with identical service intervals.

### 06 Ergonomic screed console

> The height and position of the console are easily adjusted. The high-contrast color display can be read clearly from all angles.

### 07 Easy transport

> The machine can be prepared quickly and easily for transport on a low-bed trailer. Even the hardtop can be folded down to transport position using a manual hydraulic pump.

# SCREEDS TO MEET ALL NEEDS

**Two screed options are available for the SUPER 1700-3i: The paver can be combined with the VF 500 for multivariable width applications or the VR 500 for mainline applications.**

VÖGELE VF 500 screed, with unequal-width front-mounted extensions for multivariable width applications. Maximum paving width is 19 ft. 6 in. (5.95 m) with bolt-on extensions.

VÖGELE VR 500 screed, with rear-mounted extensions for mainline applications. Maximum paving width is 21 ft. (6.4 m) with bolt-on extensions.

## Uniform screed heating

of screed plates, tamper bar and pressure bars for uniform surface courses

## Much shorter preheating time

thanks to intelligent generator management of the electric heating system even when the engine is idling

## Hydraulic crown adjustment

The crown can be conveniently adjusted at the press of a button on the screed operator's console.

## Alternating mode for screed heating

alternately powering one half of the screed heating system



## VÖGELE > GOOD TO KNOW



### Electric screed heating

A consistent surface texture is achieved by uniform heating of the screed plates. With the engine running at minimum rpm, the time required for the screed to reach operating temperature is reduced substantially due to an intelligent generator management system.

# VF 500 EXTENDING SCREED WITH FRONT-MOUNTED EXTENSIONS

for multivariable width applications

The VF 500 Extending Screed is equipped with extending units mounted in front of the main screed and was developed especially for the VÖGELE 8-foot pavers. This screed is eminently suitable for the requirements prevailing in road construction in North America and Australia.

The VF 500 is ideal for applications which require a variable paving width, such as car parks with islands and light masts, roads for residents only, urban roads with manhole covers, gas or water connections, junctions on highways or work on country roads, i.e. jobs which involve paving around obstacles.

## Screed telescoping system

Robust, large-scale guidance system featuring high-precision operator control ensures excellent screed stability, resulting in top-quality paving.

VÖGELE screeds are renowned in the industry worldwide for their high precision and robustness. The VF 500 screed is designed specifically for the North American market, and provide one key feature above all: speed. The screed consistently meets the demands of paving at high speed and across widely varying paving widths. The telescopic guidance system, for example, enables very smooth and precise width adjustment.

The L-shaped frame also provides high rigidity in longitudinal and transverse directions, while allowing controlled torsion. This means the screeds can be adapted very well to a wide variety of paving situations, including when installing speed bumps. The hydraulic bolt-on extensions also enable the paving team to vary the working width quickly and precisely.

- 01 Crown**  
Crowns of -2% to +5% are easy to set.
- 02 Crown Control**  
The continuous screed plate of the main screed paves precise crowns.
- 03 Screed telescoping system**  
The sturdy guide rods can be extended at two speeds.
- 04 Slope**  
Sloping extension up to 10%.
- 05 Berm**  
The optional berm is available in two different widths: 12 or 18 inches.



# VR 500 EXTENDING SCREED WITH REAR-MOUNTED EXTENSIONS

for almost unlimited applications

**Uniform screed heating**  
for uniform surface courses

**Much shorter preheating time**  
thanks to intelligent generator management

**Hydraulic side plates**  
with easy adjustment of height and inclination

**Hydraulic crown adjustment**  
at the press of a button on the screed operator's console

When paving large widths, absolute line and level accuracy is a decisive criterion for first-class results, regardless of pave width or layer thickness.

The VR 500 impresses with its extensive capabilities, and is thus the perfect choice for medium and large road construction projects.

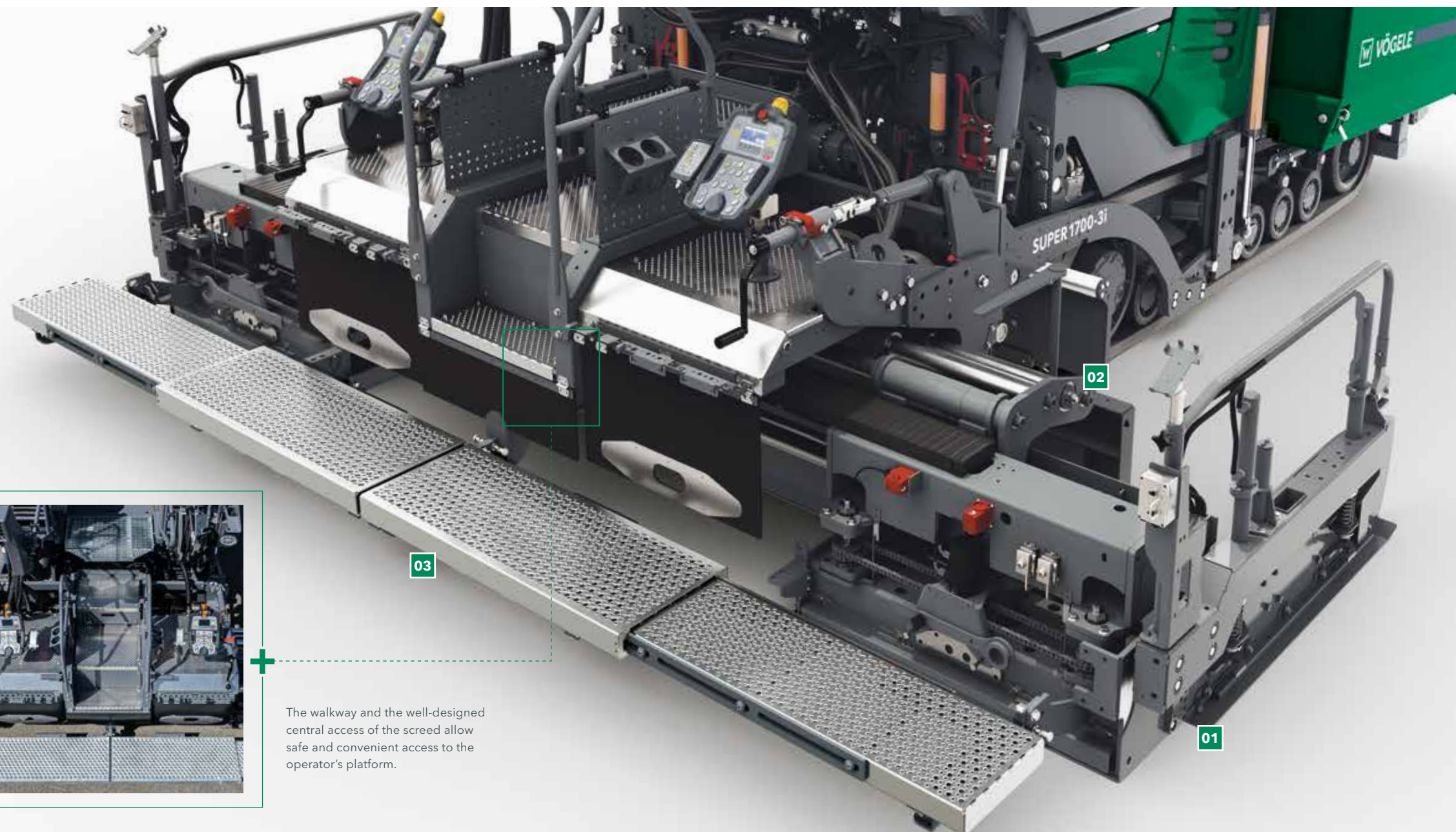

## 01 Outstanding paving characteristics

- > The optimal geometry of the smooth sheets ensures that the screed has particularly stable floating properties.
- > The cross profile can be set independently of the extensions' adjustment in height, ensuring the greatest degree of variability.
- > With the VR 500, slopes of up to 10% can be installed.
- > The edger can be adjusted with regard to inclination in order to allow the installation of several panels next to each other. This allows the transition to the existing roadway to be adapted (Safety Edge).

## 02 Two-stage telescoping system

- > The precise two-stage telescoping system gives the screed a particularly high level of stability and forms the basis for good installation results.
- > When paving with a slope, the entire guide is inclined using hydraulic extensions.

## 03 Innovative electric screed heating

- > In order to optimize compaction performance and create a smooth surface structure, the screed plates are heated across the entire width of the screed. The standard heating elements distribute heat evenly throughout the screed. The sheets are well insulated at the top so that 100% of the heat is directed to where it is needed: the point of contact between the surface and the mixture. Sophisticated control technology enables automatic control of the screed heating.

03

02

01

The walkway and the well-designed central access of the screed allow safe and convenient access to the operator's platform.

## VF 500 EXTENDING SCREED

Stability and variability are not mutually exclusive, as the front-mounted VF 500 Extending Screed from VÖGELE proves. With a basic width from 8 ft. to 15 ft. 6 in. (2.45 m to 4.75 m) and a maximum paving width of 19 ft. 6 in. (5.95 m) with bolt-on extensions it is the ideal tool for multivariable width applications and mainline paving. The unique VÖGELE telescoping system allows screed width control, accurate to the millimeter.

The variability is also evidenced in the range of possible profiles: crowns, transverse slopes and berms are set once and then built perfectly from the start to the end of paving process. The compacting system provides great mat texture and excellent compaction. So for the SUPER 1700-3i, the VF 500 Extending Screed is the perfect match.



### VF 500

#### Paving widths

- > Infinitely variable range from 8 ft. to 15 ft. 6 in. (2.45 m to 4.75 m)
- > Maximum paving width through bolt-on extensions:
  - > 17 ft. 6 in. (2 x 12 in.) / 5.35 m (2 x 30 cm)
  - > 19 ft. 6 in. (2 x 24 in.) / 5.95 m (2 x 60 cm)

#### Compacting system

- > VF 500 V with vibration

VF 500 V with 24 in. (60 cm) bolt-on extensions

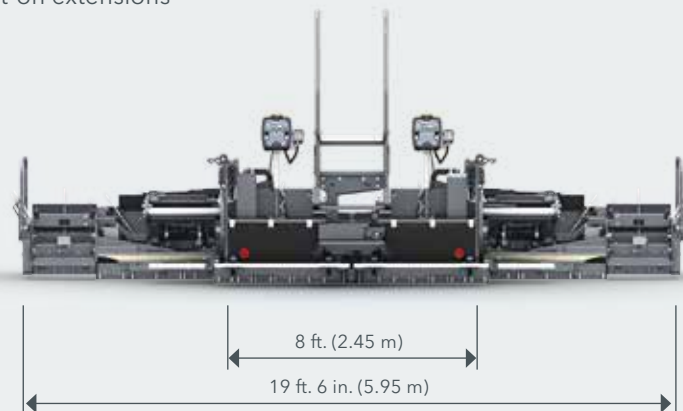

## VR 500 EXTENDING SCREED

The VR 500 Extending Screed is tailored to meet the requirements of the North American and Australian markets, but the hydraulic extensions are located behind the basic screed, as they are on the extending screeds. A special feature is the structure of the hydraulic extensions: this supports the construction of pavement profiles with a slope of up to 10 % towards the edge of the road.

In combination with the 8-foot SUPER 1700-3i paver, the screed's sturdy design makes it especially suitable for paving roads up to 21 ft. (6.4 m) wide with high precision and at high pave speeds.



### VR 500

#### Paving widths

- > Infinitely variable range from 8 ft. 4 in. to 15 ft. 6 in. (2.55 m to 4.9 m)
- > Maximum paving width through bolt-on extensions:
  - > 18 ft. (2 x 12 in.) / 5.5 m (2 x 30 cm)
  - > 20 ft. (2 x 24 in.) / 6.1 m (2 x 60 cm)
  - > 21 ft. (2 x 29 in.) / 6.4 m (2 x 75 cm)

#### Compacting systems

- > VR 500 V with vibration

VR 500 V with vibration

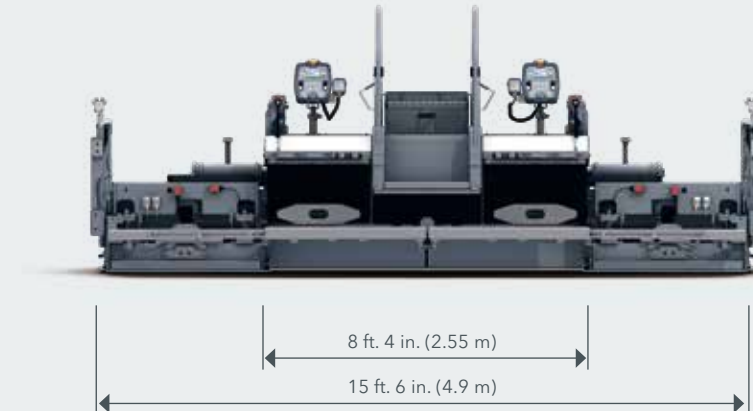

# WIRTGEN GROUP CUSTOMER SUPPORT

Service you can rely on.

You can have confidence in reliable, swift support from us during the entire life cycle of your machine. Our wide range of services is ready with the right solution to every challenge you face.



## Service

We keep our service promise with swift, straightforward assistance - on the job site or at our professional workshops. Our service team is trained to a professional standard and dedicated tools ensure that repair, care and maintenance tasks are completed quickly. We can support you with customised service agreements on request.

> [www.wirtgen-group.com/service](http://www.wirtgen-group.com/service)



## Spare Parts

WIRTGEN GROUP original parts and accessories assure the long-term reliability and availability of your machines. Our experts will also be pleased to advise you about optimised wear part solutions to suit your application. Our parts are available all over the world at all times and are easy to order.

> [parts.wirtgen-group.com](http://parts.wirtgen-group.com)



## Training

The WIRTGEN GROUP brands are specialists in their field with decades of experience in applications; our customers benefit from this expertise. In our WIRTGEN GROUP training courses, we are delighted to pass our knowledge on to you, customised to suit both operators and servicing staff.

> [www.wirtgen-group.com/training](http://www.wirtgen-group.com/training)



## Telematics solutions

Construction machines with leading technology and perfected telematics solutions work hand-in-hand in the WIRTGEN GROUP. The Operations Center\* - the platform for digital solutions for process, machine and service optimization - allows you not only to simplify maintenance planning for your machines but also to increase your productivity and cost-effectiveness.

> [www.wirtgen-group.com/telematics](http://www.wirtgen-group.com/telematics)

\*John Deere Operations Center™ (formerly WITOS) is currently not available in all countries. Please consult your responsible branch or dealer if you have any questions in this area.

# ALL THE FACTS AT A GLANCE

SUPER 1700-3i Tracked Paver



## TECHNICAL DATA

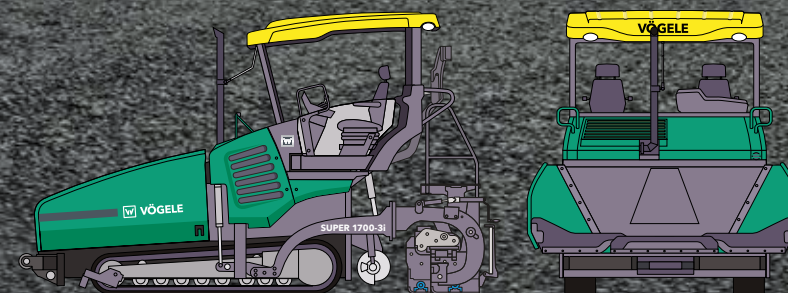

## SUPER 1700-3i

- > Maximum paving width: 21 ft. (6.4 m)
- > Maximum laydown rate: 770 tons/h (700 tonnes/h)
- > Layer thickness: up to 12 in. (30 cm)
- > Transport width: 8 ft. 6 in. (2.59 m)

**Wirtgen America, Inc.**

6030 Dana Way  
Antioch, TN 37013  
USA

T: 615 501-0600  
F: 615 501-0691

 [www.wirtgen-group.com/america](http://www.wirtgen-group.com/america)



For more information, scan the QR code.