



SCHAEFF

A **YANMAR** BRAND

MINI EXCAVATOR



TC222

HOW DO YOU START WITH A MINI AND MAKE A...



TC14_a



TC16_a



TC19_a



TC22_a

XL

MINI EXCAVATOR



WHAT DOES A GOOD MINI EXCAVATOR MEAN TODAY?

Very simple: the ability to reliably do more.

With these new models, you mini-excavate in XL format: High digging forces, functional design, more room. Schaeff offers four models in the 1.5-2.0 ton segment. From the rental version to the high-end configuration for demanding construction site deployment. All equipped with high performance genes.



TRADITION MEETS PROGRESS

The Schaeff philosophy – conventional construction, Knickmatik™ cylinder and top-mounted cylinder – was retained. A completely new machine was constructed around these elements, from high performance brand components to the new driver's cab.

“MADE IN GERMANY”

Machine Engineering Made in Germany – this is our claim: The XL mini excavators are completely designed and built in our plant in Crailsheim, Germany.

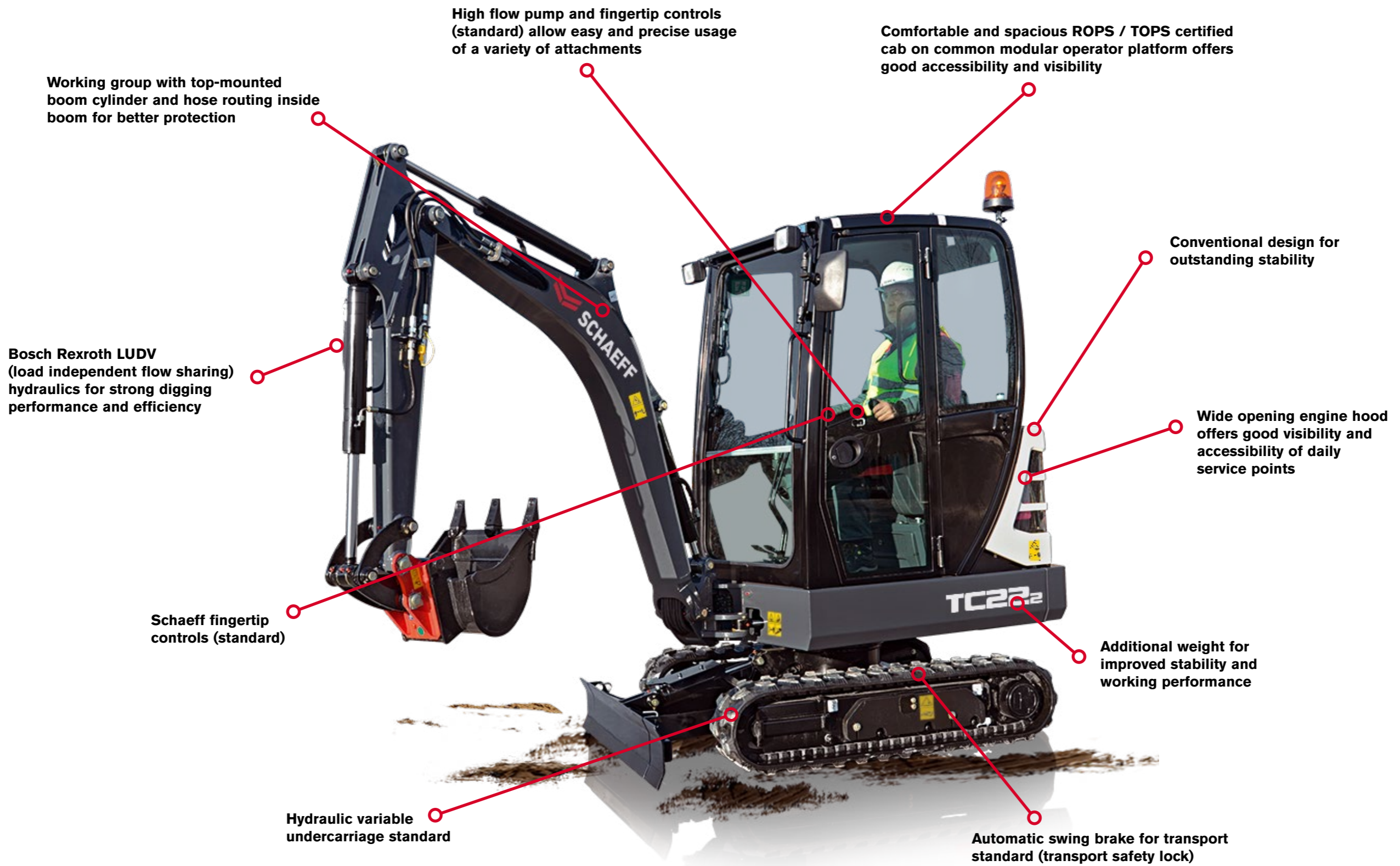

Working group with top-mounted boom cylinder and hose routing inside boom for better protection

High flow pump and fingertip controls (standard) allow easy and precise usage of a variety of attachments

Comfortable and spacious ROPS / TOPS certified cab on common modular operator platform offers good accessibility and visibility

Conventional design for outstanding stability

Wide opening engine hood offers good visibility and accessibility of daily service points

Bosch Rexroth LUDV (load independent flow sharing) hydraulics for strong digging performance and efficiency

Schaeff fingertip controls (standard)

Additional weight for improved stability and working performance

Hydraulic variable undercarriage standard

Automatic swing brake for transport standard (transport safety lock)



TC14₂



TC16₂



TC19₂



TC22₂

Operating weight kg	
Cab	1610
Canopy	1500
Machine width mm	990 - 1340
Engine power kW (hp)	10.4 (14.1)
Engine manufacturer	Kubota D 722
Max. digging depth m	
Standard dipperstick	2.26
Long dipperstick	-

Operating weight kg	
Cab	1650
Canopy	1570
Machine width mm	990 - 1340
Engine power kW (hp)	10.4 (14.1)
Engine manufacturer	Kubota D 722
Max. digging depth m	
Standard dipperstick	2.26
Long dipperstick	2.46

Operating weight kg	
Cab	1840
Canopy	1760
Machine width mm	990 - 1340
Engine power kW (hp)	12.0 (16.3)
Engine manufacturer	Kubota D 902
Max. digging depth m	
Standard dipperstick	2.54
Long dipperstick	2.74

Operating weight kg	
Cab	2010
Canopy	1930
Machine width mm	990 - 1340
Engine power kW (hp)	12.0 (16.3)
Engine manufacturer	Kubota D 902
Max. digging depth m	
Standard dipperstick	2.54
Long dipperstick	2.74

EQUIPMENT

- Digging equipment: Dipperstick 950 mm
- LUDV hydraulics
- Cab version optional
- Automatic swing brake (transport security)
- Rubber track, 230 mm wide (short pitch)

EQUIPMENT

- Digging equipment: Dipperstick 950 mm standard Dipperstick 1150 mm optional
- LUDV hydraulics
- 1st and 2nd additional control circuit optional
- Hydraulically adjustable undercarriage optional
- Rubber track, 230 mm wide (short pitch)
- 2 travel speeds optional
- Automatic swing brake (transport security)

EQUIPMENT

- Digging equipment: Dipperstick 950 mm standard Dipperstick 1150 mm optional
- LUDV hydraulics
- Schaeff Fingertip Control optional
- 1st and 2nd additional control circuit optional
- Hydraulically adjustable undercarriage standard
- Automatic swing brake (transport security)
- Rubber track, 230 mm wide (short pitch)
- 2 travel speeds
- Comfort seat

EQUIPMENT

- Digging equipment: Dipperstick 950 mm standard Dipperstick 1150 mm optional
- LUDV hydraulics
- Schaeff Fingertip Control standard
- 1st additional control circuit standard
- 2nd additional control circuit optional
- Hydraulically adjustable undercarriage standard
- Automatic swing brake (transport security)
- Rubber track, 230 mm wide (short pitch)
- 2 travel speeds
- Comfort seat

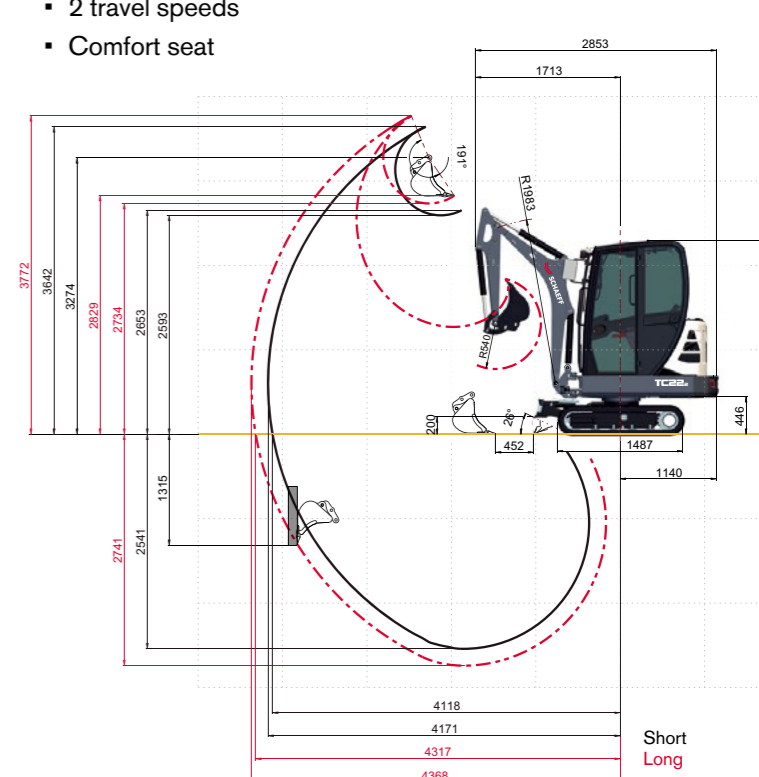
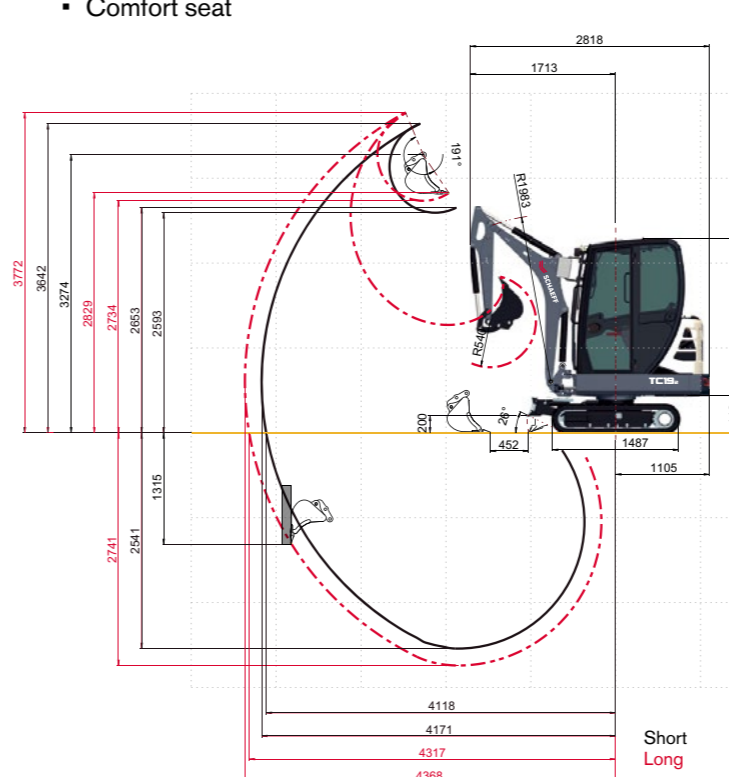
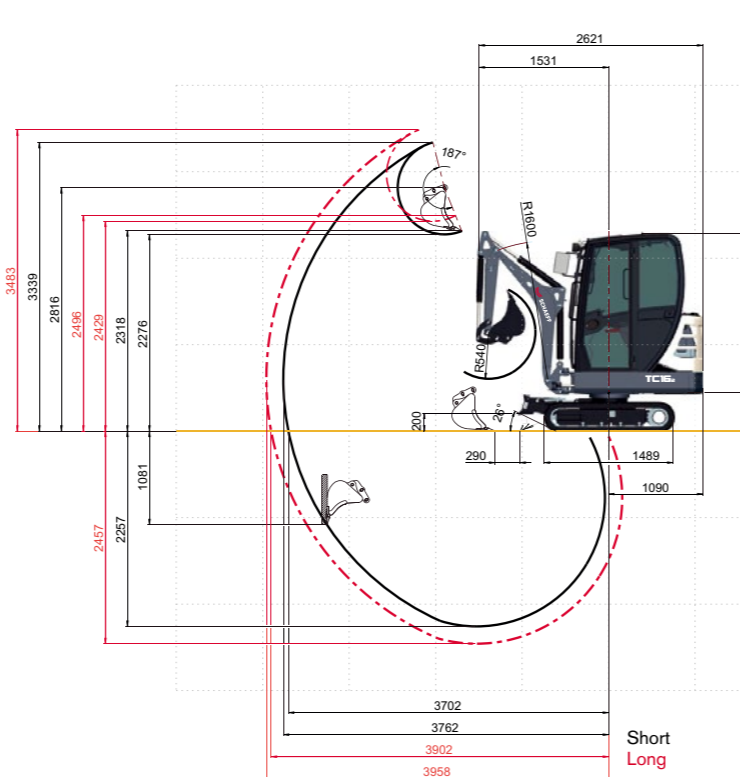
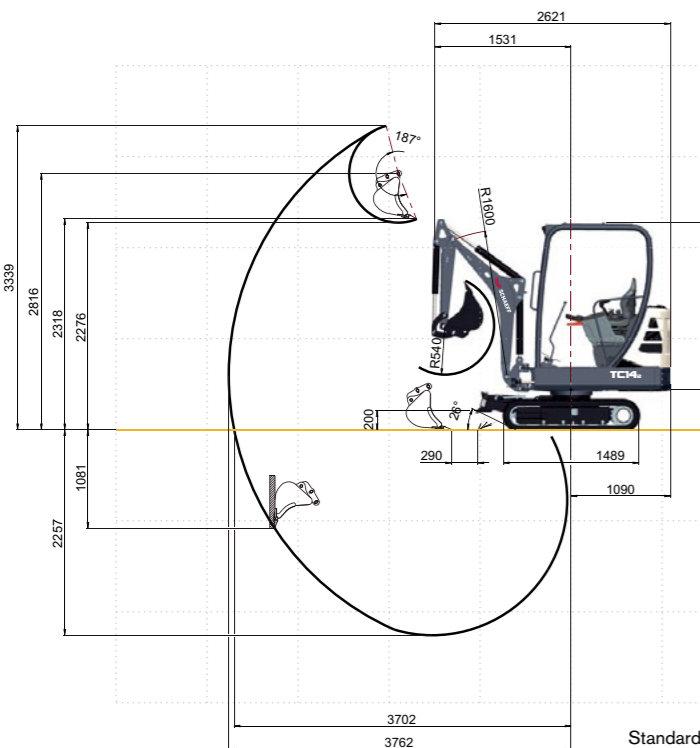

XL DIGGING PERFORMANCE

HOW DOES A PRODUCTIVE MACHINE COME INTO BEING?

Very simple: combine high-performance components with good ideas.

ENGINE AND HYDRAULIC SYSTEM

Compared to current competitors' models, the mini excavator offers an average 20 % more work capacity, for example, when quickly digging trenches.

The LUDV (load independent flow sharing) hydraulics is offered by only a few models in this class. Even for extreme terrain, the bucket digs in powerfully and is completely filled.

SECOND ADDITIONAL CONTROL CIRCUIT

For precise operation of attachment tools, the second auxiliary control circuit is electrically proportional – optional from TC16-2 and upward. The driver exerts extremely precise control via a joystick (Schaeff Fingertip Control) – one special feature that is normally seen only in excavators of a higher class.

SCHAEFF KNICKMATIK®

The Schaeff Knickmatik® with adjustable articulated boom system is ideal for working along walls or embankments. The total articulation angle is an impressive 120°. The swing cylinder does not project over the track and so is protected from damage.

SCHAEFF FINGERTIP CONTROL

With the Schaeff Fingertip Control, the electrically proportional actuation of the hydraulic functions is extremely simple with a thumb wheel on the joystick. With it, the operator can precisely regulate the oil flow from "zero" to "full", an advantage when controlling the attachment devices such as clamshell buckets or swing buckets. Also available on the right joystick for the first control circuit and on the left joystick for the second control circuit.

CRAWLER UNIT

The undercarriage is adjustable from 990 to 1340 mm. This guarantees full mobility on construction sites with narrow passageways/gates and offers exceptional stability on difficult terrain.





XL WORKSTATION

HOW CAN PERFORMANCE BE INCREASED INDEPENDENTLY FROM TECHNOLOGY?

Very simple: with a workplace that makes the driver better.

ROOMY CAB

The new XL cab (ROPS/TOPS-certified) offers room and comfort like the "big ones". For quick entry, the console can be raised for more space to get in the cab. The footwell offers place enough – even for shoe sizes 15 and larger. In general, the workplace can be individually arranged to the size of the driver. The large glass area allows optimal visibility of the attachment tools and the work environment.

For optimal communication on the construction site, the right window can be opened to floor level.

Canopy version

The machines are also available in canopy versions. With safety equipment such as the lockable storage compartment.

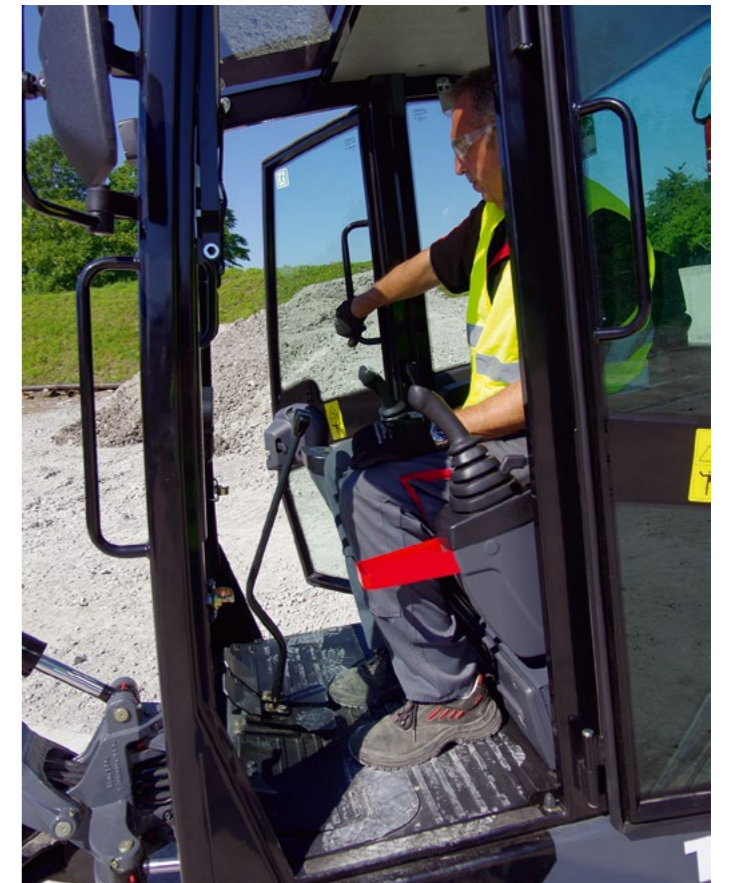

XL EASE OF USE

WHAT DOES “USER-FRIENDLY” MEAN?

Very simple: the combination of intuitive control and safe working.

WELL PROTECTED

With Schaeff-specific construction features, damage is avoided right from the start: Because of the upper position of the top-mounted cylinder, there is never contact between the piston rod and the loading edge when loading trucks. The Knickmatik™ cylinder was deliberately placed on the left so it is protected from damage in case of a collision. The boom can be swiveled to both sides at full digging depth.



HYDRAULIC HOSES

The hydraulic hoses on the working device are well protected by the boom, or are located snugly along the boom.

TRANSPORT

Because of the automatic swing brake, locking the upper carriage for transport is impossible to forget.

ERGONOMICS

Particular focus was placed on ergonomics in all models; for example, the blade lever offers an integrated travel speed controller. This feature makes leveling and digging much easier.



DISPLAY

Instrument display with tank level, operating hour counter and more. An optical signal for faulty functions.





XL SERVICE

WHAT DOES DAILY SERVICE COME DOWN TO?

**Very simple:
minimizing time and effort.**

Downtimes and service costs are reduced overall.

To save time during daily service, easy access and combined service points are key elements. Only one key is needed for all locks.

The engine hood opens upward widely so daily inspection points are directly accessible or can be monitored through gauge glasses or, on most models, are already visible from outside. Direct fueling from canisters is easily possible at working height.



HIGH STANDARD

RIGHT FROM THE START, INSIDE AND OUT

ENGINE / FUEL SYSTEM

- Double air filter system
- Fuel filling ports at working height

UNDERCARRIAGE

- Rubber track, 230 mm wide (short pitch)

HYDRAULIC SYSTEM

- Pressure accumulator for emergency reduction
- Straight-ahead driving function
- Automatic swing brake (transport security)

SAFETY SYSTEM

- Engine safe-start device in left control console

WORK EQUIPMENT

- Additional control circuit up to end of dipperstick
- Cab/canopy-mounted working floodlight
- LUDV (load independent flow sharing) hydraulics

SAFETY CAB

- ROPS (Roll-Over Protective Structure)
- TOPS (TIP-Over Protective Structure)
- Weight-dependent adjustable comfort seat
- Safety belt
- Hydraulic pilot control with adjustable handrests
- Cab heating with windshield defroster
- Front windshield opening system with gas-dampened support
- Battery main switch
- 12 V connection
- Cabling for loudspeakers and antenna, radio plug-in compartment
- Side mirror
- Accelerator pedals
- Right window opens wide for optimum ventilation, visibility and communication
- Stow and store possibilities for tools, mobile phone and beverages

CANOPY

- ROPS (Roll-Over Protective Structure)
- TOPS (TIP-Over Protective Structure)
- Weight-dependent adjustable comfort seat
- Safety belt
- Hydraulic pilot control with adjustable handrests
- 12 V connection
- Accelerator pedals
- Lockable storage compartment under the operator's seat
- Stow and store possibilities for tools, mobile phone and beverages



GOOD OPTIONS

OPTIMIZE YOUR MINI EXCAVATOR FOR USE

- Crane lifting beam
- Weatherproof roof
- Rubber track, 230 mm wide (long pitch)
- Prepared installation for radio plug-in module (radio plug-in compartment, antenna, 2 loudspeakers)
- Theft prevention system
- Switches and cabling for rotating beacon
- Additional work headlight and rotating beacon
- Load hook
- Load-retaining valve
- Oil variants
- Protective grid
- Fire extinguisher
- Travel motion alarm



THE SCHAEFF ADVANTAGE

HOW DOES A MINI EXCAVATOR BECOME PART OF YOUR COMPANY?

**Very simple:
with our additional services.**

PAINTING SERVICE – SHOW YOUR COLORS

So one matches the other: we paint with exactly your company colors.



BrandIt® – THE SERVICE FOR YOUR LOGO ON THE MACHINE.

At Schaeff, your company takes a prominent place. Our engine hoods offer plenty of room for your logo and therefore, your market presence. As desired, with our support.

Talk about our BrandIt® service with your Schaeff partner.





COMPACT PORTFOLIO

MADE IN CRAILSHEIM

FACTORY-APPROVED SPARE PARTS

WHAT KEEPS YOUR SCHAEFF MINI EXCAVATOR READY TO OPERATE OVER THE LONG TERM?

Very simple: the original.

Schaeff spare parts ensure sustainable performance and efficiency for your machine. Order processing and service are fast: Schaeff dealers can order over 100,000 parts, from safety belts and control components to axles and filter elements. More than 95 % of the parts are shipped within 24 hours.

Contact your local Schaeff partner. There you will find further information and can order factory-tested spare parts.



Manufacturing compact construction machines is our expertise and our great passion. We have dedicated ourselves to this task for over 75 years – over 30 of them at our Crailsheim, Germany, location.

Our ideas are part of the history of construction machines; for instance, the Knickmatik® or the top-mounted cylinder. And still today, our expertise dictates the market. Our expertise pays dividends for our customers: through extremely productive and reliable construction machines.

Mini crawler excavators

10 models. Operating weights from 1.5 to 5.0 tons

Midi crawler excavators

4 models. Operating weights from 5.65 to 12.5 tons

Compact wheeled excavators

3 models. Operating weights from 7.4 to 11.0 tons

Compact wheel loaders

5 models, bucket capacities from 0.5 to 1.8 cubic meters

SPECIFICATIONS

ENGINE

Manufacturer, model	Kubota, D902 Tier 4 final
Type	3-cylinder diesel engine
Bore x stroke	72 x 73.6 mm
Displacement	898 cm ³
Power rating acc. to ISO 14396 @ 2300 rpm	12.0 kW (16.3 HP)
Torque max. @ 1800 rpm	52.1 Nm
Air filter with safety cartridge and maintenance switch	
Cold-starting aid	Glow plugs

ELECTRICAL SYSTEM

Nominal voltage	12 V
Battery	12 V / 44 Ah
Generator	12 V / 40 A
Starter	1.4 kW
Lighting system:	1 work light front left on the cab / canopy (auxiliary headlamps optional)

TRANSMISSION

Two-stage hydrostatic travel drive with axial piston variable displacement motor and reduction gear, fully enclosed. "Straight-Travel" function. Travel brake valves for downhill travel

Travel speed, 1 st gear	2.2 kph
Travel speed, 2 nd gear	4.2 kph

Forwards and backwards respectively. Manual switching via button on dozer lever.

UNDERCARRIAGE

Torsion-proof welded design. Hydraulically retractable/extendable undercarriage provided as standard. Maintenance-free crawler-type undercarriage. Idler suspension with hydraulic crawler-chain tensioning. Sliding plate at the top

Range of adjustment, outside edge of crawler chains	990 – 1340 mm
Width rubber tracks (short pitch)	230 mm
Total length (undercarriage)	1490 mm
Number of rollers per side	4
Track width	760 – 1110 mm
Gradeability	max. 60%
Drawbar pull 1 st / 2 nd speed range	1400 / 780 daN

DOZER BLADE

Independent of drive train, sensitive control via separate hand lever	
Width x height	1340 x 235 mm
Dozer cut below ground	160 mm
Dozer lift above ground	200 mm
Slope angle	25°

STEERING

Independent individual control of crawler chains, also counterwise. Sensitive actuation via manual levers, combined with pedals, foot rest on pedal console

SWING SYSTEM

Internally toothed ring gear	
Swing speed	0 – 9 rpm

SWING BRAKE

Hydrostatic drive, also acts as wear-resistant brake. Additional spring-loaded multi-disc brake. Considered as transport security



FLUID CAPACITIES

Fuel tank	27 l
Hydraulic system (incl. tank 21 l)	26 l

KNICKMATIK®

Lateral parallel adjustment of boom arrangement at full dig depth.

Angle of articulation / lateral adjustment left	59° / 414 mm
Angle of articulation / lateral adjustment right	60° / 555 mm

OPERATING DATA, STANDARD EQUIPMENT

Operating weight according to ISO 6016: Cab with 600 mm bucket, quick-attach system, 1 st additional control circuit, rubber tracks, including driver, full fuel tank	2010 kg
--	---------

Operating weight according to ISO 6016: Canopy with 600 mm bucket, quick-attach system, 1 st additional control circuit, rubber tracks, including driver, full fuel tank	1930 kg
---	---------

Transport weight: Cab, tank half full, with quick-attach system, w/out bucket	1885 kg
---	---------

Transport weight: Canopy, tank half full, with quick-attach system, w/out bucket	1805 kg
--	---------

Total length (travel position)	2853 mm
--------------------------------	---------

Total length (trailer transport position)	4133 mm
---	---------

Total height (top of canopy / cab)	2277 / 2294 mm
------------------------------------	----------------

Total height (travel position)	2673 mm
--------------------------------	---------

Total width (undercarriage)	990 – 1340 mm
-----------------------------	---------------

Total width of uppercarriage	980 mm
------------------------------	--------

Uppercarriage tail swing	1140 mm
--------------------------	---------

Uppercarriage front swing	1440 mm
---------------------------	---------

Working envelope, bucket heaped (also with 600 mm bucket):	
180°	2580 mm
360°	2883 mm

Swing clearance	446 mm
-----------------	--------

Reach max.**	4171 / 4368* mm
--------------	-----------------

Digging depth max.**	2541 / 2741* mm
----------------------	-----------------

Loading height approx.**	2593 / 2734* mm
--------------------------	-----------------

Highest reachable height**	3642 / 3772* mm
----------------------------	-----------------

Bucket rotation angle	191°
-----------------------	------

Bucket digging force acc. to ISO 6015	18,850 N
---------------------------------------	----------

Stick digging force acc. to ISO 6015	11,000 / 9720* N
--------------------------------------	------------------

Specific ground pressure:	
Excavator cpl.	0.30 daN/cm ²

* with dipperstick 1150 mm (optional)

** Dimensions apply to machine standing on level ground, but can be increased by tilting the machine using the blade.

SPECIFICATIONS

HYDRAULIC SYSTEM

Pump capacity, max.	36.3 l/min
Working pressure	250 bar

Dual gear pump	
----------------	--

Load independent flow distribution (LIFD) for all working movements and travel drive

Simultaneous independent control of all functions

All excavator movements servo-controlled, ISO

All functions are proportionally controllable

Hydraulic oil cooler

Full flow filtration through return filter

Cylinders for boom, dipper arm and articulation with end position damping at both ends

Bucket retract function with end-position damping

Safety shutdown activated by exit barrier

Additional control circuit as standard: Schaeff 'Fingertip' control (electro proportional) for additional control circuit for work attachments on right joystick, including holding function for continuous operation, actuation via rollers

Additional control circuit with bypass for pressure-reduced return quantity

Hydraulic power to the couplings:

Pump capacity (pressure-controlled)

@ 145 bar 36.3 lpm

@ 210 bar 21.1 lpm

Max. working pressure 210 bar

Diagram shows P/Q provided on couplers:

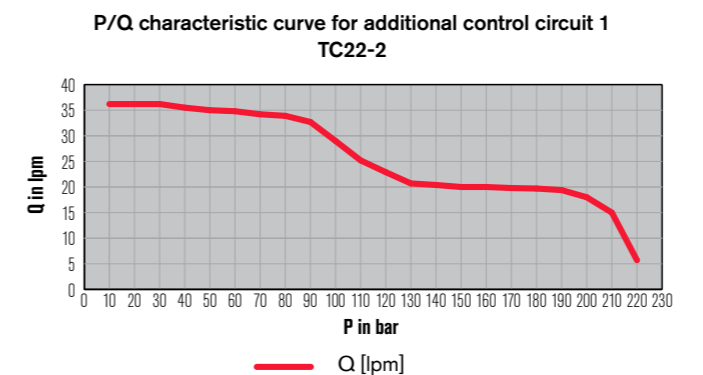

CAB (STANDARD)

Spacious, sound-insulated full-vision steel cab, FOPS*** (acc. to ISO 3449), ROPS and TOPS (acc. to ISO 12117) certified

Very good all-round visibility, lean vertical support members

Safety glass

Front window supported by pneumatic springs, slidable under cab roof

Fixed window part without frame which obstructs the forward view

Door with large access on left hand side

Foldable console on left hand side for large entry access

Right door as emergency exit

Matching locks of hood, ignition and tank cap

Central connector for electrical cable

Wiper washer with wiper for windscreen

Interior light, coat hook

Operator's seat (comfort version), fabric-covered:

Longitudinal and back tilt adjustment

Continuous weight adjustment as per operator's weight

Safety belt

Armrests height adjustable without tools

Cables for radio installation kit

Preparation for antenna

Large storage compartment under the operator's seat

Heating (water) with 2-speed fan and 4 adjustable exhaust nozzles

Temperature controller in cab

Storage pocket behind the operator's seat

Storage compartment for mobile phone (near 12V outlet)

1 left-hand outside rear-view mirror, foldable in front of windshield

1 working floodlight front left as standard

Display, fuel gauge, hour meter and warning lights

Fuse box easily accessible from outside of the cab

Very good ergonomics

Ergonomically arranged dozer blade lever

Fast / slow switch on dozer blade lever

Yellow beacon, radio, immobilizer (anti-theft device), working floodlights prepared for optional installation

*** FOPS-approved only with skylight guard (optional)

CANOPY

Robust steel pipe construction. 4 support members for the best all-round visibility

1 working floodlight front left

FOPS (acc. to ISO 3449), ROPS and TOPS (acc. to ISO 12117) certified

Operator's seat (standard version), imitation leather:

Longitudinal and back tilt adjustment

Continuous weight adjustment as per operator's weight

Safety belt

Large lockable storage compartment under the operator's seat

Storage pocket behind the operator's seat

Display, fuel gauge, hour meter and warning lights

Easy and quick change of canopy to cab and vice-versa (< 1 hour)

Yellow beacon, immobilizer (anti-theft device), working floodlights prepared for optional installation

Reduction weight canopy 80 kg

CRANE TRANSPORT

Crane lifting beam for cab and canopy

SOUND LEVEL VALUES

Noise emission ambience L _{wa} cab / canopy	93 / 93 dB (A)
--	----------------

Noise emission cab L _{pa} cab / canopy	79 / 79 dB (A)
---	----------------

Sound level values measured in compliance with Directive 2000/14/EC and EN474

VIBRATION VALUES

Effective values of acceleration for whole body	less than 0.5 m/s ²
---	--------------------------------

Effective values of acceleration for hand-arm	less than 2.5 m/s ²
---	--------------------------------

Vibration values in compliance with Directive 2006/42/EC and EN474

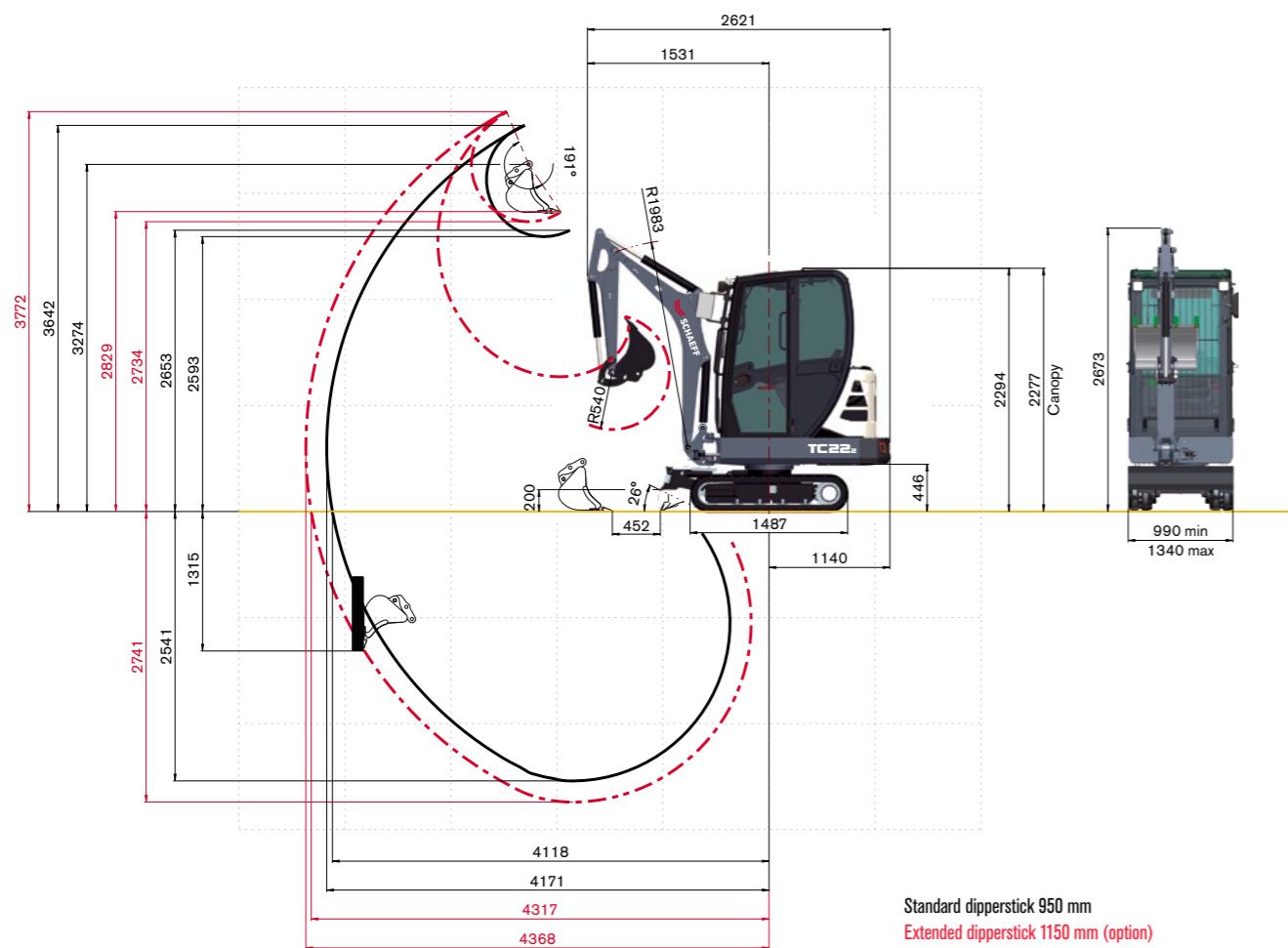

Bucket hinge height Dipperstick 950 mm	Load radius from center of ring gear																			
	1.5 m				2.0 m				2.5 m				3.0 m				3.5 m			
	UR	UE	UR	UE	UR	UE	UR	UE	UR	UE	UR	UE	UR	UE	UR	UE	UR	UE	UR	UE
2.0 m	-	-	-	-	-	-	-	-	0.45	0.45	0.36	0.36	0.37	0.37	0.29	0.37	-	-	-	-
1.0 m	-	-	-	-	0.79	0.79	0.47	0.75	0.54	0.54	0.35	0.53	0.43	0.43	0.27	0.42	0.35	0.35	0.21	0.33
0.0 m	-	-	-	-	0.76	0.76	0.42	0.70	0.56	0.56	0.32	0.53	0.43	0.43	0.26	0.42	0.33	0.33	0.20	0.28
-0.75 m	-	-	0.59	0.76	0.62	0.62	0.41	0.57	0.47	0.47	0.31	0.45	0.37	0.37	0.24	0.34	-	-	-	-

Bucket hinge height Dipperstick 1150 mm	Load radius from center of ring gear																			
	1.5 m				2.0 m				2.5 m				3.0 m				3.5 m			
	UR	UE	UR	UE	UR	UE	UR	UE	UR	UE	UR	UE	UR	UE	UR	UE	UR	UE	UR	UE
2.0 m	-	-	-	-	-	-	-	-	0.31	0.31	0.33	0.29	0.28	0.28	0.29	0.28	0.26	0.26	0.20	0.28
1.0 m	-	-	-	-	0.63	0.63	0.44	0.60	0.44	0.44	0.31	0.43	0.35	0.35	0.25	0.34	0.29	0.29	0.19	0.29
0.0 m	-	-	-	-	0.69	0.69	0.41	0.64	0.50	0.50	0.28	0.50	0.37	0.37	0.21	0.37	0.28	0.28	0.20	0.27
-0.75 m	-	-	0.51	0.77	0.54	0.54	0.39	0.51	0.39	0.39	0.29	0.38	0.28	0.28	0.29	0.21	0.21	0.21	0.22	0.21

All values in tons (t) were determined acc. to ISO 10567 and include a stability factor of 1.33 or 87% of the hydraulic lifting capacity. All values were determined with quick-attach system but without bucket. In case of mounted-on work attachments, the deadweights of the work attachments must be deducted from the permissible operating loads

Working equipment: Rubber tracks

Abbreviations: UR = Undercarriage retracted, UE = Undercarriage extended

DIMENSIONS

Abb. 1, 2:
Baggern über die gesamte Breite der Maschine

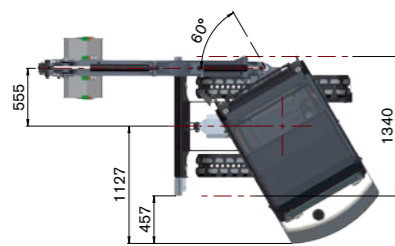

Fig. 3:
Transport position - trailer transport

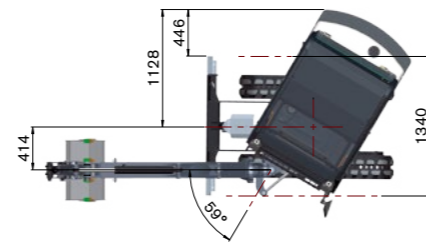
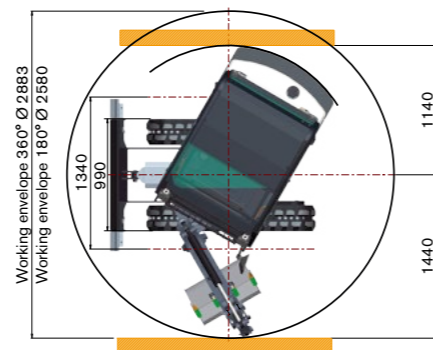
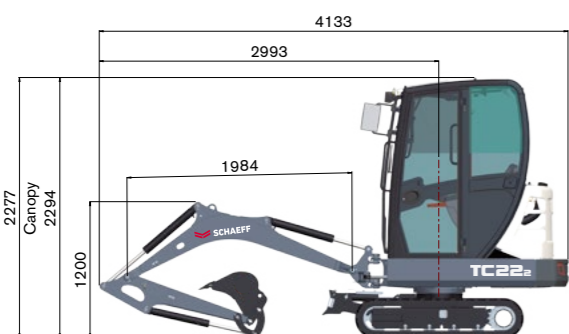

Fig. 4:
Working envelope



WORK ATTACHMENTS

BUCKETS

Bucket, QAS	250 mm wide, capacity 21 l, 27 kg
Bucket, QAS	300 mm wide, capacity 26 l, 30 kg
Bucket, QAS	400 mm wide, capacity 37 l, 35 kg
Bucket, QAS	500 mm wide, capacity 48 l, 41 kg
Bucket, QAS	600 mm wide, capacity 59 l, 46 kg
Ditch-cleaning bucket, QAS	1000 mm wide, capacity 91 l, 79 kg
Swing bucket, QAS	1000 mm wide, capacity 49 l, 79 kg

GRABS

Clamshell grab GL 1250, grab swing brake	set of shells 250 mm wide, capacity 45 l
Ejector	

OTHER WORK ATTACHMENTS

Hydraulic hammer	Cutting unit
Augers	Quick-change adapter for hydraulic hammer
Bolt-on load hook for bucket rod	Further work attachments available on request

OPTIONAL EQUIPMENT

CRAWLER CHAIN OPTIONS

Rubber tracks (long pitch), 230 mm wide

BOOM OPTIONS

Monobloc boom, with extended dipperstick 1150 mm

HYDRAULIC SYSTEM

Schaeff 'Fingertip' control (electro proportional) incl. second additional control circuit on left joystick, including holding function for continuous operation, actuation via rollers

Quick couplings for control circuit for work attachments (hammer hydraulics) incl. open return

Quick couplings for 2nd additional control circuit

Biodegradable hydraulic oil / ester-based HLP 68 (Panolin)

Hose-rupture / load-retaining valves for boom and dipperstick cylinders

Supplementary set "Clamshell grab opening / closing", without quick couplings, for standard dipperstick

Quick couplings for supplementary set "Clamshell grab opening / closing"

OPERATOR'S STAND

Operator's seat (standard version), imitation leather

CAB

Rain guard

Lighting package: Cab-mounted working floodlight front right and rear right, boom-mounted working floodlight, yellow beacon

Fire extinguisher, ABC powder 2 kg

FOPS - skylight guard

Radio set installation kit (speakers)

OTHER OPTIONAL EQUIPMENT

Mechanical quick-attach system

Quick-attach system, mechanical (genuine Lehnhoff system), type MS01 or MS03

Back-up alarm, signal-horn (can be switched off)

Immobilizer, transponder key

Further optional equipment available on request

Crane lifting gear

Safety package: hose-rupture / load-retaining valves for boom and dipperstick cylinders, fire extinguisher, immobilizer, motion alarm

Special colour options



Yanmar Compact Germany GmbH
Kraftwerkstrasse 4
74564 Crailsheim, Germany

www.schaeff-yanmar.com